



# Extinguishing technology CO<sub>2</sub> HP

## Ad-on part cylinder CO<sub>2</sub> HP

### Support steel cylinder



### Approvals

(VdS approval is not required!)



- 1) Listed system:
  - CO<sub>2</sub> HP LCP (UL-File EX27301)
- 2) Part of the system approval:
  - CO<sub>2</sub> HP LCP (FM23FPUS0180)

### SAP designation

part no. 931200: Support steel cylinder

### Maintenance

Visual check during the maintenance intervals specific to the fire extinguishing system, but at least annually.

Designation	Part no.	Weight
Support steel cylinder	931200	0.42 kg (0.93 lbs)

### Material / surface

Ring cylinder suspension .....aluminum casting alloys  
 .....EN 1706 AC-43000 KF  
 Rod compl. support .....brass / steel, galvanized  
 Fork joint DIN71751 A8x16 .....steel, galvanized  
 Hex. nut DIN555 M8 .....steel, galvanized

### Application

The support steel cylinder is used in cylinder racks, single cylinder systems and pneumatic release devices mechanical and serves to support of pilot control cylinders and extinguishing cylinders.

### Note

The usage under outdoor exposure is not allowed, this means, that the support steel cylinder may not be exposed to rain, snow, severe dust exposure or the like.

### Dimension drawing

Dimensions in mm (inch)

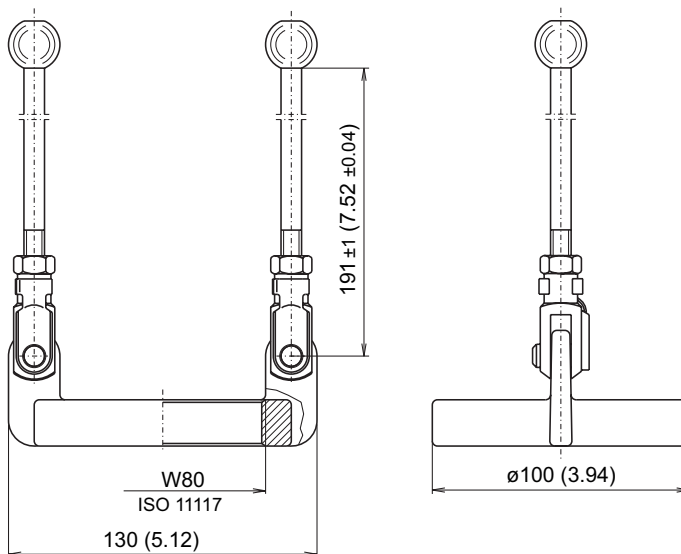

214-210\_006 / A101 / 2023-Nov-22 / en  
The contents of this publication are subject to modifications without notice. All rights reserved.  
1/1

Trusted above all.

